



GOODWIN BARSBY
LEICESTER, ENGLAND



Manufactured in the UK

Mk5 Series Single Toggle Jaw Crushers

- The Goodwin Barsby range of heavy duty single toggle jaw crushers offer proven reliability with more than 125 years of design, manufacture and engineering experience.
- The new Mk5 series jaw crushers incorporate engineering enhancements without compromising the proven design.
- The heavy duty thermally stress relieved main frame, cast steel jawstock, forged eccentric shaft and oversized spherical roller bearings are designed to withstand the most demanding of applications.
- Offering all round performance with high outputs, good product shape, proven reliability and economical running costs. The rugged and reliable design incorporates improved geometry producing 'Extra Bite' in the crushing action, a proven success in hard rock mining and quarrying applications worldwide.

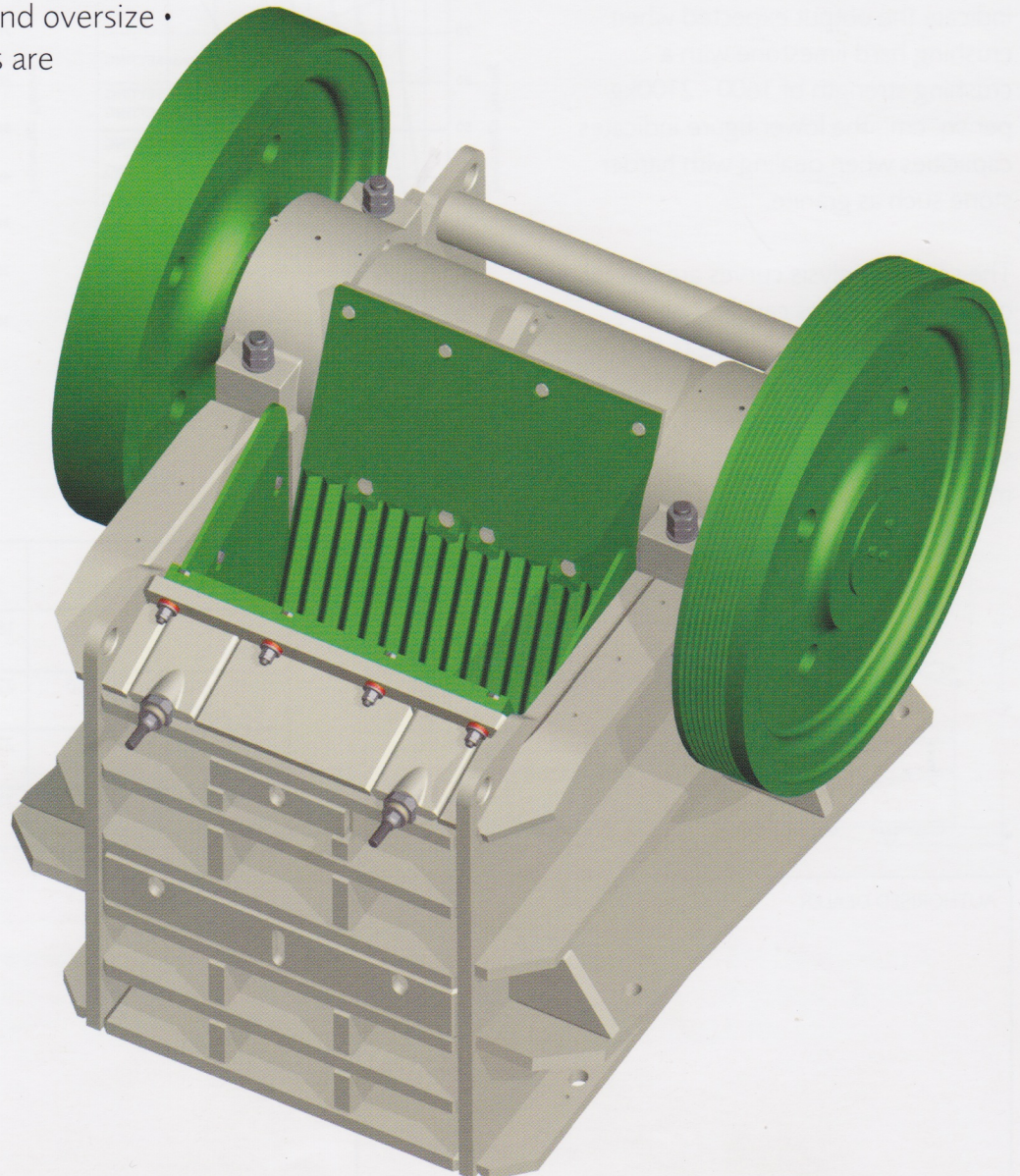

Mk5 Series Single Toggle Jaw Crusher Specifications

Capacities Approx (Tonnes per hour)

Size of Mouth mm	Min CSS mm	Closed Side Setting (mm)														KW (HP)	RPM	
		25 (1")	40 (1 1/2")	50 (2")	60 (1 1/4")	75 (3")	90 (3 1/2")	100 (4")	125 (5")	150 (6")	175 (7")	200 (8")	225 (9")	250 (10")	275 (11")			300 (12")
760 x 455 30" x 18"	50 (2")			40-50	50-60	68-85	75-95	80-100	100-120	120-140							45-55 (60-75)	320
1065 x 610 42" x 24"	60 (2 1/4")				70-95	95-125	105-140	120-160	140-190	160-220							70-90 (100-125)	250
1065 x 760 42" x 30"	90 (3 1/2")						120-160	140-190	165-225	190-260	220-300	250-330	280-360				110-132 (150-175)	250
1220 x 915 48" x 36"	125 (5")								200-255	230-300	265-345	300-390	340-430	380-470			150-170 (200-225)	250

Screening Analysis Notes on crusher capacities and screening analysis

Capacities are based on crushing stone weighing 1600kg per cubic metre in broken form. The higher figures indicate the output expected when crushing hard limestone with a crushing strength of 1600 - 2100kg per sq. cm., the lower figure indicates capacities when dealing with harder stone such as granite.

The screen analysis curves are typical only. Actual results can only be determined by crushing tests as they will vary with the type of rock being handled, the method of feed and the size of pieces being fed into the machine.

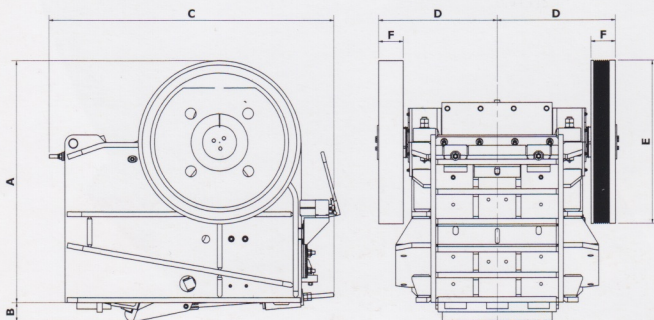
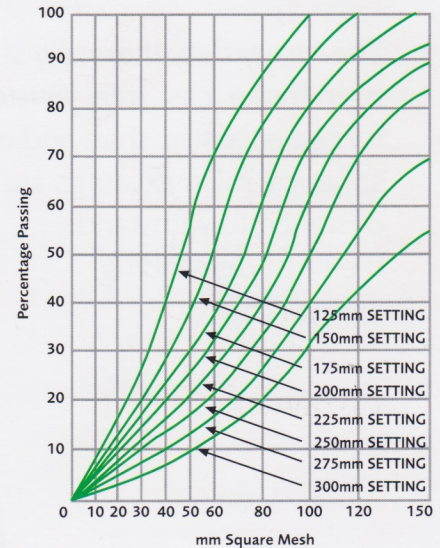
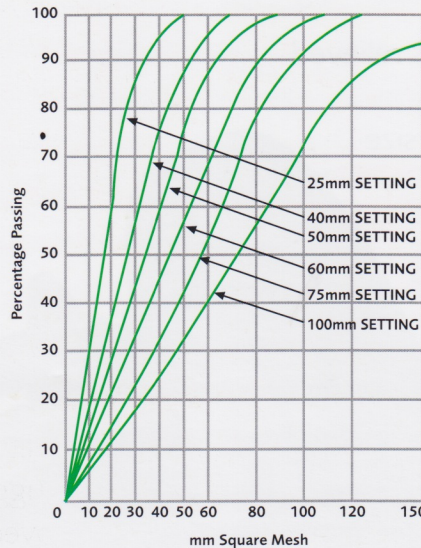

Size of Mouth	Wt KG	A	B	C	D	E	F
760 x 455 30" x 18"	9296	1805	150	2185	1025	1145	205
1065 x 610 42" x 24"	20830	2255	235	2650	1140	1525	230
1065 x 760 42" x 30"	27992	2755	215	2920	1385	1525	265
1220 x 915 48" x 36"	41657	2175	215	3300	1525	1675	375

Authorised Re-Seller of GOODWIN BARSBY Crushers & Feeders

Port & Quarry Supplies, Moira Road, Ashby, Leicestershire LE65 2GA, United Kingdom

T: +44 (0) 1530 414 358

E: sales@pqs.uk.net

W: www.pqs.uk.net